

RANGE
CWE 525

GRU CINGOLATA COMPATTA
COMPACT CRAWLER CRANE
KOMPAKTKRAN AUF ROLLSCHIENEN



BG LIFT
by Brennero Gru 



CWE 525 Range
The best instruments for Your Work

BG LIFT
by Brennero Gru 



Posizione bassa / Low Position / Niedrige position

Posizione alta / High Position / Hohe position

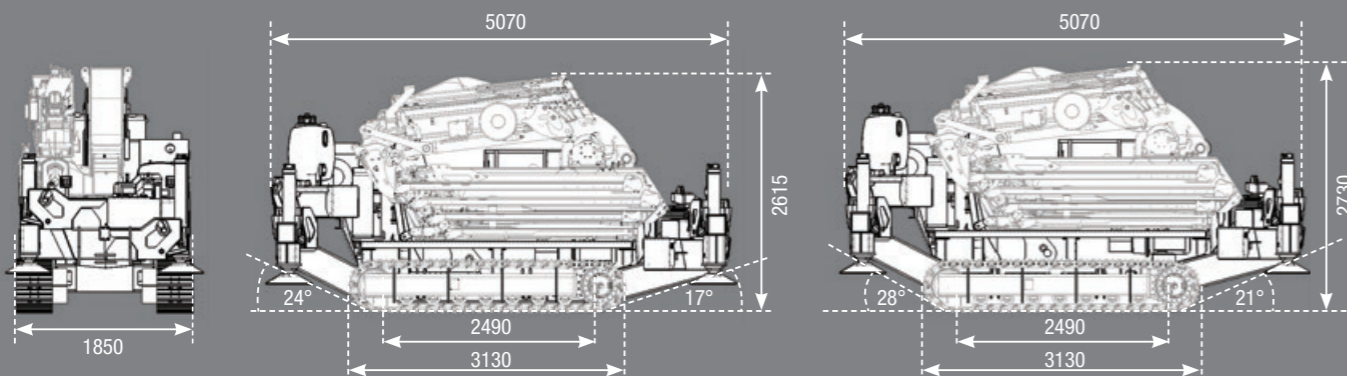

CWE 525

CWE 525. Alte performance in poco spazio

Un progetto esclusivo del Team di ricercatori di BG LIFT, realizzato con i migliori materiali e tecnologie d'avanguardia. Il miglior connubio possibile tra potenza e prestazioni abbinato ad una compattezza fino ad ora inimmaginabile. Le contenute dimensioni, unite ad una manovrabilità con movimenti millimetrici, consentono di operare in spazi estremamente ristretti, normalmente preclusi a gru di pari categoria.

Tecnologia:

Every Function Under Control Il radiocomando proporzionale multifunzione con display per controllo integrato, consente anche di visualizzare in tempo reale tutti i parametri della macchina.

No Limits Rotation La zavorra mobile montata sul carro permette la rotazione continua in sagoma.

Always Ready to Work Telaio ad "X" che consente di lavorare con gli stabilizzatori in sagoma e l'ingombro al minimo.

Easy To Drive Può stabilizzare e lavorare in terreni scoscesi.

Load & Transport La compattezza e l'ampio angolo di attacco permettono di caricare la gru utilizzando rampe corte.

Jib Over Line Lunghezza e portata del Jib da record.



CWE 525. High Performance in Tight Space

An Exclusive Project of BG LIFT Engineers Team, realized with best materials and Hi-Tech Technologies. The best possible union between Power and Performance combined to an incredible Compactness, unimaginable until today. The light dimensions and the millimetric movements manoeuvrability allow to operate in extremely Narrow spaces, normally inaccessible to other cranes of the same class.

Technology:

Every Function Under Control The multifunction proportional radio control provided with an integrated control display, permits as well to verify in real time all the parameters of the machine.

No Limits Rotation The removable Ballast mounted on the Chassis permits the continuous "in shape" Rotation.

Always Ready to Work The "X" configuration allows to operate with narrow outriggers and minimum obstruction.

Easy To Drive The Machine can level and operate on steep grounds.

Load & Transport The compactness and the wide ground clearance angle allows the crane to be loaded using Short ramp.

Jib Over Line Noteworthy Jib Length and Load.

CWE 525. Viel Leistung in wenig Platz

Dieses Projekt wurde vom Team BG Lift realisiert, mit der besten Technologie und Materialien derzeit auf dem Markt verfügbar. Die bestmögliche Zusammensetzung zwischen Leistung und Stärke, angepasst in einer Kompaktheit die bisher unvorstellbar war. Die geringen Dimensionen, verbunden mit einer außergewöhnlichen Beweglichkeit bis auf den Millimeter genau, ermöglichen die Arbeit an Orten, wo man normalerweise mit Kräne gleicher Kategorie und Konventioneller Bauart, nicht hinkommt.

Technologie:

Every Function Under Control Die Proportionale Multifunktions-Fernbedienung mit Display und Integraler Kontrolle, ermöglicht den kompletten Überblick aller Parameter der Maschine. **No Limits Rotation**

Das auf dem Rahmen montierte mobile Ausgleichsgewicht, ermöglicht eine bedingungslose Rotation des Krans. **Always Ready to Work** Die

X- Konfiguration des Rahmens ermöglicht das Arbeiten mit eingefahrenen Stabilisatoren bei minimalen Platz-Dimensionen. **Easy To Drive**

Ermöglicht auch auf weichen und unebigen Grund eine Stabilisierung des Krans. **Load & Transport** Die Kompakte Bauart des Krans, ermöglichen aufgrund der Bodenfreiheit, eine problemlose Auf und Ab-Ladung für den

Transport. **Jib Over Line** Rekord-Länge bzw. Leistung des Jib.

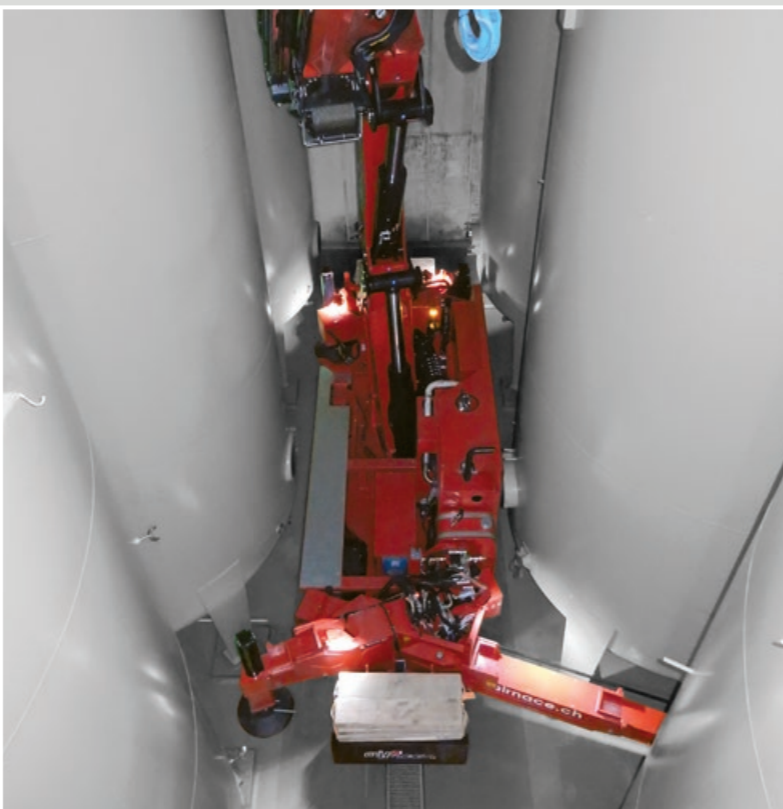



CWE 525 RT Rough Terrain

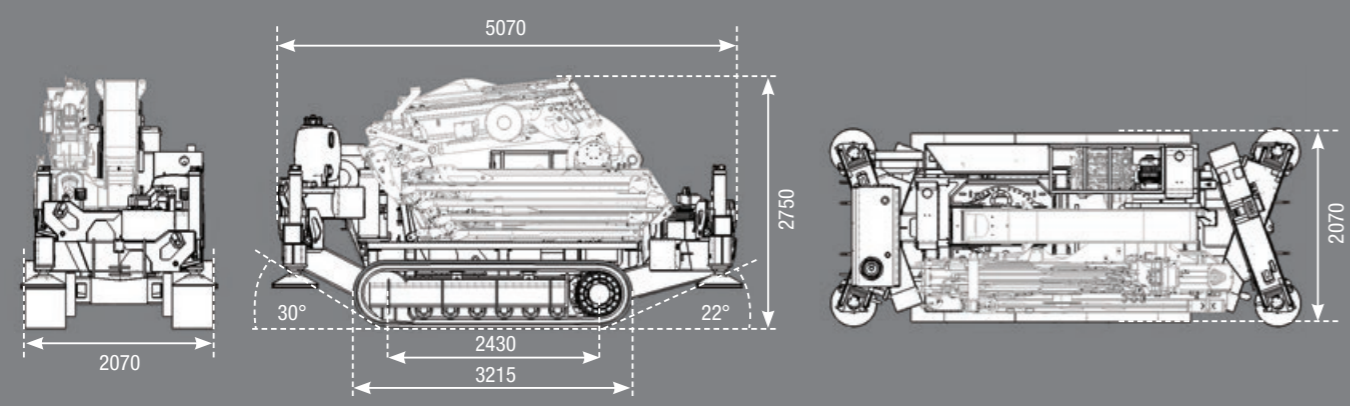

CWE 525 RT. Potenza, compattezza e off-road

La versione RT (Rough Terrain) aggiunge ulteriori possibilità di impiego della macchina.
La maggior potenza del motore Diesel (85 Kw) e la maggiore coppia del carro cingolato migliorano le prestazioni in condizioni di impiego gravose su terreni fortemente accidentati e fangosi.

Tecnologia:

Every Function Under Control Il radiocomando proporzionale multifunzione con display per controllo integrato, consente anche di visualizzare in tempo reale tutti i parametri della macchina.

No Limits Rotation La zavorra mobile montata sul carro permette la rotazione continua in sagoma.

Always Ready to Work Configurazione ad "X" che consente di lavorare con gli stabilizzatori in sagoma e l'ingombro al minimo.

Easy To Drive Può stabilizzare e lavorare in terreni scoscesi.

Load & Transport La compattezza e l'ampio angolo di attacco permettono di caricare la gru utilizzando rampe corte.

Jib Over Line Lunghezza e portata del Jib da record.



CWE 525 RT. Power, Compactness and OFF-Road.

The RT Version (Rough Terrain) give the machine Further employment Possibilities.
The higher Power of the Diesel Engine (84 Kw) and the major crawler torque improve the performance during heavy employment conditions on strongly Mud and Rough grounds.

Technology:

Every Function Under Control The multifunction proportional radio control provided with an integrated control display, permits as well to verify in real time all the parameters of the machine.

No Limits Rotation The removable Ballast mounted on the Chassis permits the continuous "in shape" Rotation.

Always Ready to Work The "X" configuration allows to operate with narrow outriggers and minimum obstruction.

Easy To Drive The Machine can level and operate on steep grounds.

Load & Transport The compactness and the wide ground clearance angle allows the crane to be loaded using Short ramp.

Jib Over Line Noteworthy Jib Length and Load.

CWE 525 RT. Leistung, Kompaktheit und Off-Road

Die Versione RT verfügt über gesonderte Eigenschaften und Einsatz der Maschine.
Die höhere Leistung des Diesel Motors (85Kw), und bessere Drehmoment verbessern die Leistung der Maschine im Gelände und Schlamm.

Technologie:

Every Function Under Control Die Proportionale Multifunktions-Fernbedienung mit Display und Integraler Kontrolle, ermöglicht den kompletten Überblick aller Parameter der Maschine. **No Limits Rotation**

Das auf dem Rahmen montierte mobile Ausgleichsgewicht, ermöglicht eine bedingungslose Rotation des Krans. **Always Ready to Work**

Die X- Konfiguration des Rahmens ermöglicht das Arbeiten mit eingefahrenen Stabilisatoren bei minimalen Platz-Dimensionen. **Easy To Drive**

Ermöglicht auch auf weichen und unebigen Grund eine Stabilisierung des Krans. **Load & Transport**

Die Kompakte Bauart des Krans, ermöglichen aufgrund der Bodenfreiheit, eine problemlose Auf und Ab-Ladung für den Transport. **Jib Over Line**

Rekord-Länge bzw. Leistung des Jib.



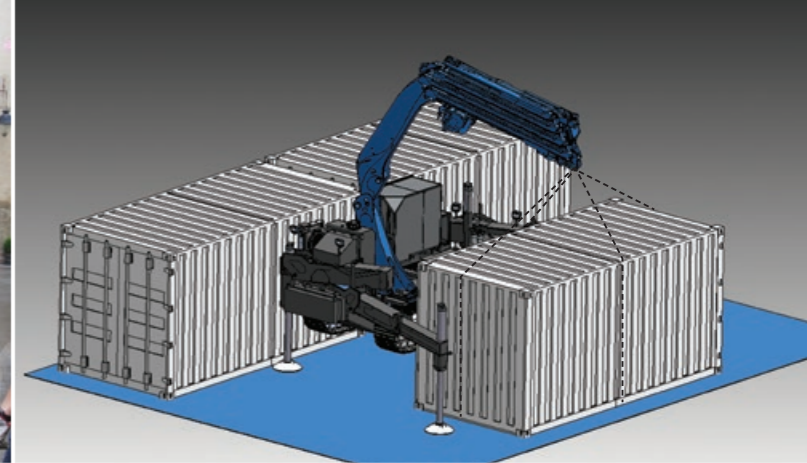

CWE 525 RANGE / TECHNOLOGY APPLICATIONS



Stabilizzazione in pendenza

Gli stabilizzatori delle gru **CWE 525**, con il sistema a traverse incrociate, conferiscono al basamento della gru un'incomparabile resistenza torsionale mantenendo estremamente compatte le dimensioni di ingombro in assetto di trasferimento.

I cilindri di stabilizzazione, robusti con corsa maggiorata, facilitano la tenuta della gru su terreni fortemente scoscesi.

Sloping Stabilization

The outriggers of **CWE 525 Range**, Provided With Cross Beams System, confer to the Crane Chassis an incomparable torsion resistance always keeping extremely Compact the machine Dimensions in rest position.

The outriggers cylinders, solid with extended stroke, Simplify the Crane Endurance on strongly steep grounds.

Stabil auch in Hang-Situationen

Die Stabilisatoren der Gamma **CWE 525**, verfügen über eine Kreuz-Traverse, die dazu beitragen beim basieren des Krans, extremen widerstand auf Torsion zu leisten, um somit die kompakten Dimensionen bei Bewegung des Krans zu erhalten.

Die Zylinder der Stabilisatoren, sind robust und haben einen längeren Hub, ermöglichen somit den Kran eine sichere Stabilisation auf weichen und unebigen Untergrund.

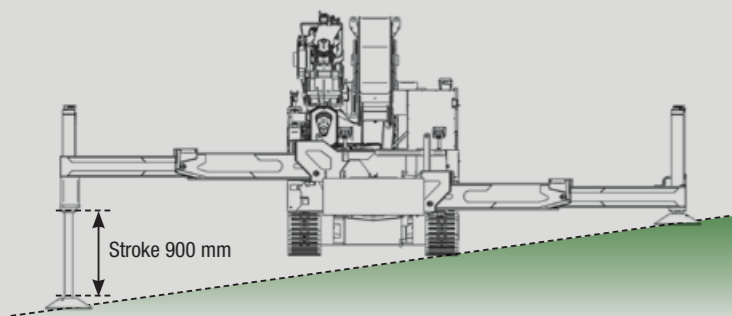

Gestione del carico

Un largo impiego di acciai speciali ad alto limite di snervamento come lo **STRENX 1300**, consente di contenere il peso a vantaggio delle prestazioni, soprattutto nelle portate più esterne in punta al JIB.

Load Management

A large Employment of high enervation limit special steels, such as **STRENX 1300**, allow to limit the weight in order to take advantage of the performance; especially with more external loads on the top of the Jib.

Zuladung

Der Einsatz von speziellem Stahl wie **STRENX 1300**, ermöglichen einen ideale Gewichtverlagerung das sich Vorteilhaft auf Leistungen auswirkt, speziell bei Einsätzen mit weit ausgefahrenen JIB.

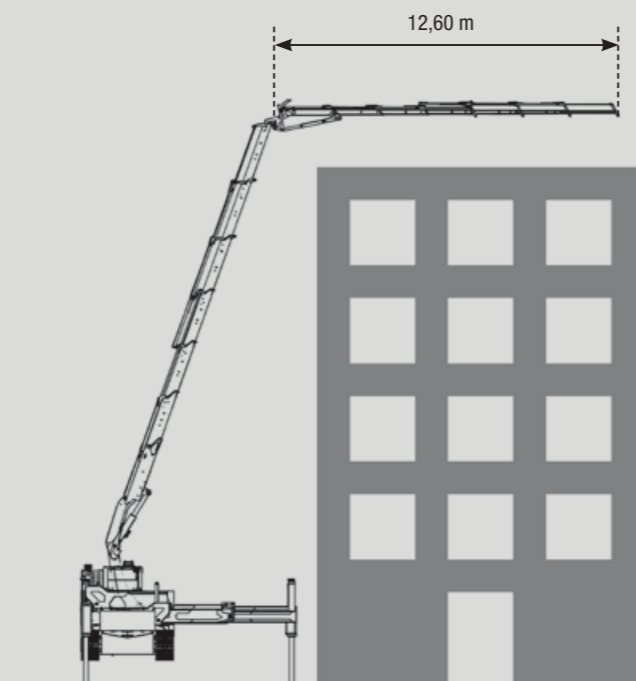

Trasporto

Gli ampi angoli d'attacco consentono di caricare la macchina su autocarri anche con rampe corte. Facilitando le manovre e ottimizzando i tempi di carico.

Transport

The generous ground clearance angle permit to load the machine as well on truck with short ramps; simplifying the manoeuvres and optimizing loading time.

Transport

Die Bauart des Krans, ermöglichen aufgrund der Bodenfreiheit, eine problemlose Auf und Ab-Ladung für den Transport, im geringen Zeitraum.

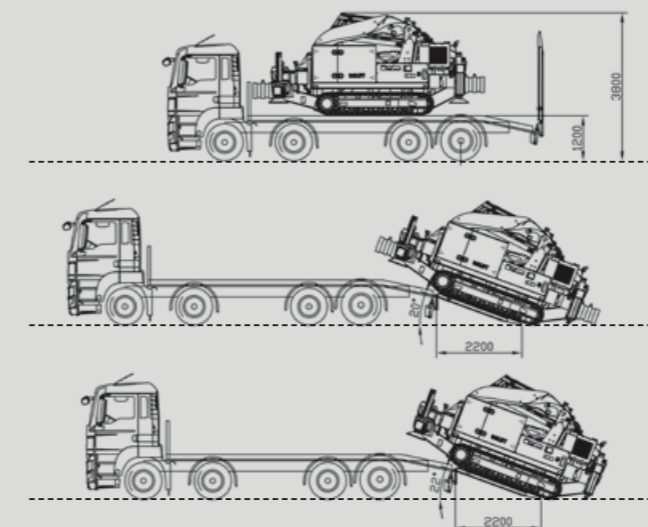

Prestazioni a corto raggio

Le gru **CWE 525** è costruita con baricentri molto bassi, i quali, uniti alla geometria delle traverse incrociate, consentono di sviluppare la piena potenza ed abbracciare carichi pesanti e voluminosi (Macchine utensili e altro) operando a ridosso degli stessi in spazi ed altezze contenute.

“Short ray” Performance

CWE 525 is Built with very low barycentres which, combined to the Cross Beams Geometry, Permit to develop the full power and cover heavy and voluminous loads (Machines Tools and other) operating close to the load in reduced spaces and heights.

Leistung bei kurzem Radius

Die Bauart der **CWE 525** hat einen niedrigen Schwerpunkt, das zusammen mit der Geometrie der Traversen, eine hohe Belastung bzw. Beladen des Krans (z.B. Arbeitsmaschinen), bei geringen Platzmöglichkeiten ermöglichen.

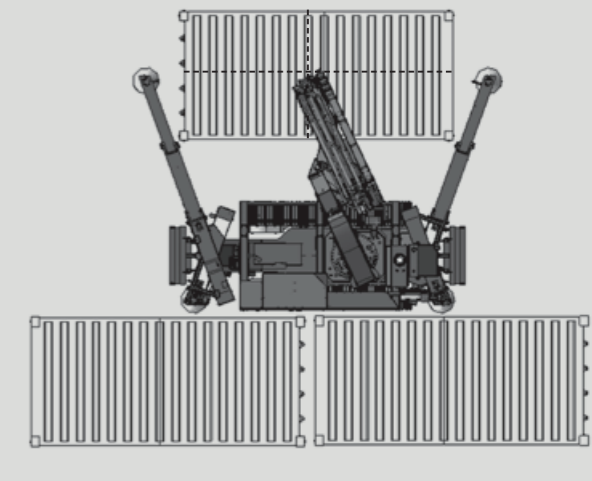



CWE 525 RANGE / TECHNOLOGY APPLICATIONS

Stabilità con limitazione del carico (Progress)

Il Sistema di controllo integrato consente alla gru infinite possibilità di stabilizzazione adeguando automaticamente il limitatore di carico alla situazione determinata dalla posizione di ogni stabilizzatore consentendo all'operatore di lavorare in sicurezza, e nel contempo, impostando configurazioni fino ad ora impensabili.

Load Limit Stability (Progress)

The integrated control system give to the Crane infinite Stabilization possibilities, Automatically upgrading the load limiting device to the situation determined by the position of each outriggers; permitting the operator to completely work in safety conditions and, simultaneously, setting configurations unthinkable until today.

Stabilität mit automatischer Abregelung des Gewichts (Progress)

Das integrierte Kontrollsystem des Krans, ermöglicht unendliche Möglichkeiten zur Stabilisierung, passt dabei automatisch den Sicherheitsregler an jede Position des Krans an, um somit das Arbeiten mit höchster Sicherheit zu ermöglichen, und zugleich eine Konfiguration des Krans, wie zuvor nicht Erdenklich.

Angolo positivo per accessi difficili (JOL)

Il secondo braccio articolato telescopico ed il Jib idraulico telescopico hanno un'operatività angolare rispettivamente di 15° e di 20° al di sopra dell'allineamento orizzontale del braccio. Tale soluzione consente di operare all'interno di edifici con la possibilità di superare ostacoli come travi, soppalchi e portoni.

Positive Angle for Hard Access

The second Articulated Telescopic Boom and the Hydraulic Jib have angular operating system respectively of 15° and 20° Over the Horizontal alignment of the boom. This situation allow to operate inside buildings and give the possibility to overcome obstacles such as lofts, front door and Beams.

Positiver Winkel für extrem schwierige Einfahrten

Der zweite gelenkte teleskopische Arm und der hydraulisch gesteuerte und teleskopische JIB, haben einen Schließwinkel von 15° und 20°, über der horizontaler Ausrichtung des Arms. Diese Lösung ermöglicht die Betreibung der Maschine auch in engen und niedrigen Gebäuden bzw. Räumlichkeiten, mit niedrigen Decken und Tore.

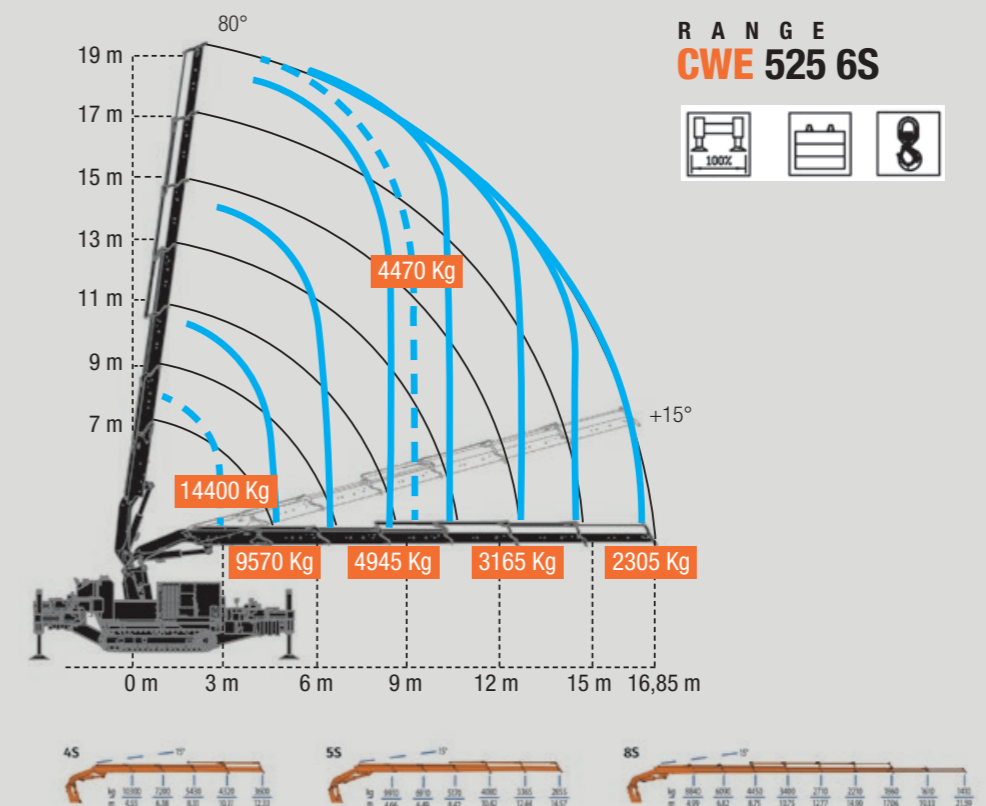
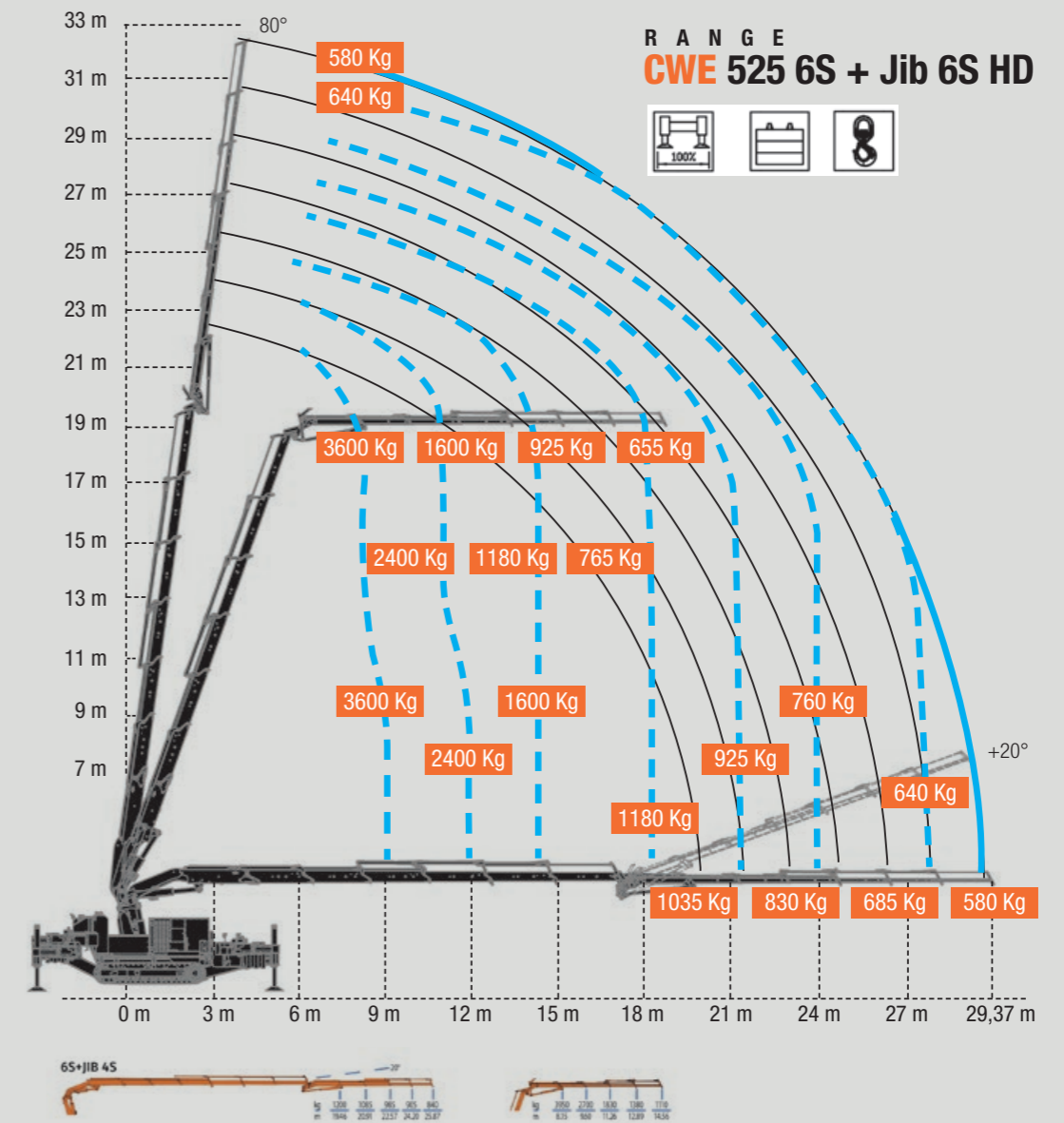
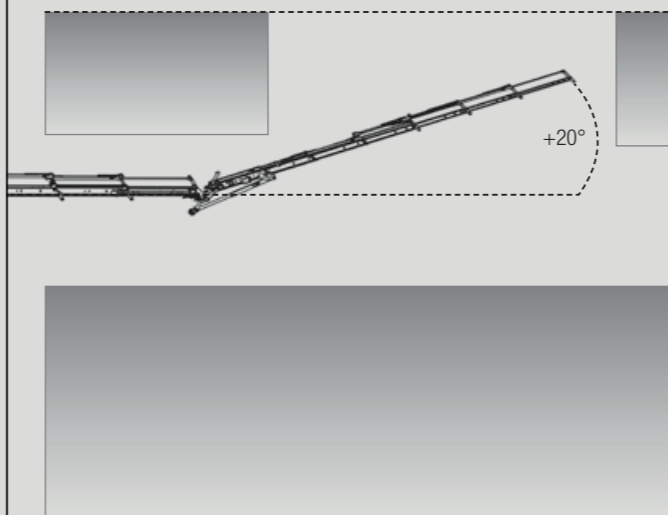
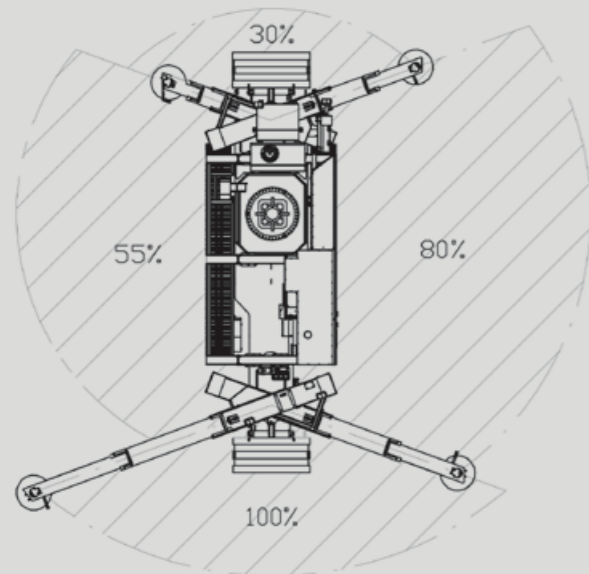

Technical data can be modified without prior notice

Technical data can be modified without prior notice



	Carico massimo gru Max capacity Traglast	14515 Kg / 3,01 m
	Raggio massimo di lavoro (versione 6S) Max outreach (6S version) Maximaler Arbeitsradius (Version 6S)	16,85 m
	Raggio massimo di lavoro con Jib idraulico (versione 6S+JIB 6S HD) Max outreach with Jib (version 6S+Jib 6S HD) Maximaler Arbeitsradius mit hydraulischem Jib (Version 6S+ Jib 6S HD)	29,40 m
	Altezza massima del braccio (versione 6S) Max hook height (6S version) Maximale Höhe des Armes (Version 6S)	20 m
	Altezza massima con Jib idraulico (versione 6S+JIB 6S HD) Max hook height with Jib (version 6S+Jib 6S) Maximale Höhe des Armes mit hydraulischem Jib (Version 6S)	32,5 m
	Angolo di rotazione-velocità Slewing angle-speed Schwenkbereich - Fahrgeschwindigkeit	Continua / 1,5 rpm Continuous / 1,5 rpm Endlos / 1,5 rpm
	Argano (optional) Winch (optional) Seilwinde (optional)	Tiro in diretta / First layer pull / Traglast 1-strangig Lunghezza fune / Rope lenght / Seillänge Velocità in tiro diretto / Speed in direct pull / Geschwindigkeit bei 1-Strang-Betrieb
	Radiocomando Radio remote control Fernsteuerung	Sanreco Can-Bus + Dispaly
	Limitatore di carico Stability control Lastmomentbegrenzer	Elettronico Electronic computergesteuert
	Stabilizzazione Stability system Abstützung	Infinite possibilità di posizionamento Dynamic stability area calculation Unendlich viele Möglichkeiten

CWE 525

	Peso degli elementi Weights Gewichte	Gru standard (Versione 6S) / Standard crane (6S Version)/ Standard Krane (Version 6S) Jib (6S) / Jib (6S) / Jib (6S) Motore elettrico 15Kw/400 V / Electric motor 15 Kw/400 V / Electromotor 15 Kw/400 v Argano / Winch / Seilwinde Zavorra Mobile / Mobile ballast / Abnehmbare Ausgleichsgewichte Pattini in gomma / Rubber pads /Rollschienen in Gummi	13200 Kg 1000 Kg 200 Kg 250 Kg 3800 Kg 135 Kg
	Trazione carro cingolato Crawler crane traction Antrieb des Raupenkrans	Trasmissione / Transmission / Antrieb Portata / Scope / Zulässige Traglast Pressione / Pressure / Druck Velocità / Speed / Fahrgeschwindigkeit Pendenza max / Max slope degree / Max. überwindbare Steigung Pressione al suolo / Max pressure on the ground / Bodendruck Larghezza pattino / Traks width / Breite des Läufer Carico max. stabilizzatore / Max. outrigger load / Maximale Belastung des Stabilisatoren	Riduttore Epicicloidale / Moto-reducer/ Planetengetriebe 160 l 225 Bar 1,2 - 2,2 K/h 25° 1,05 Kg/Cm ² 350 mm 18000 daN
	Motore diesel Diesel engine Diesel Motor	Marca / Brand / Marke Modello / Model / Typ Potenza max / Max power / Max Leistung Coppia max / Max torque / Maximale Drehemoment Capacità serbatoio / Tank capacity / Tankinhalt	Hatz 4H50 TICH TIER IV 55 kw / 74.8 Hp 240 Nm 75 l



DOTAZIONI STANDARD / STANDARD EQUIPMENT

- Radiocomando con display per ogni funzione del Carro, Stabilizzatori e Gru
- Rotazione continua
- Avvolgitubi sugli stabilizzatori
- Biella e forcella su ogni articolazione della gru
- Scambiatore di calore a velocità variabile
- Predisposizione per argano
- Predisposizione per il Jib
- Predisposizione per il cestello Porta operatore
- Sistema di controllo a variazione continua degli stabilizzatori
- Zavorre amovibili
- Avanzamento cingoli a 2 velocità
- Acceleratore dei giri motore
- N° 4 attacchi per il sollevamento
- N° 4 piastre amovibili per stabilizzatori
- Limitatore di carico elettronico
- Autodiagnosi
- Gru colore Giallo RAL 1007
- Carro colore RAL 9005
- Normativa di riferimento EN 12999.

- Radio remote control with display for crawler, chassis and crane function.
- Continuous rotation
- Hoses winder on the outrigger
- Links on all the crane articulations
- Variable speed oil fan cooler
- Predisposition for winch installation
- Predisposition for Jib Installation
- Predisposition for two man baskets installation
- Outriggers continuous variations Control system
- Removable ballast
- Two speed crawler translation
- Engine rpm increment
- N° 4 lifting connections
- N° 4 removable outriggers plates
- Electronic limiting device
- Auto diagnostic
- Crane color yellow RAL 1007
- Crawler color black RAL 9005
- According to EN12999.

- Fernbedienung mit Display für alle Funktionen des Rahmens (Fahrwerk), Stabilisatoren und Kran
- ungeschänkte Rotation
- Aufrollsystem für schläuche an den Stabilisatoren
- Welle und Gabelung für jeden Bewegung des Krans
- Wärmeaustauscher mit variabler Geschwindigkeit
- Vorbereitung für Winde
- Vorbereitung für JIB
- Vorbereitung für Personen-Arbeitskorb
- Kontrollsystem mit fortlaufender Variation der Stabilisatoren
- abnehmbare Ausgleichsgewichte
- zweistufige Geschwindigkeit der Gleiträder
- Beschleuniger für Drehzahl
- 4 Befestigungspunkte für das Heben der Lasten
- 4 abnehmbare plattformen für die Stabilisatoren
- Elektronische Abregelung bei Überlastung
- Auto-Diagnose
- Farben des Krans Gelb RAL 1007
- Farbe der Rahmens RAL 9005
- Übereinstimmung mit der Norm EN 12999.

OPTIONAL

- Jib idraulico con operatività 200°
- Connessione idraulica Quick-Faster
- Linee idrauliche per accessori
- Prolunghe manuali
- Ganci Ribassati
- Attacchi ribassati per ventose
- Cestelli Porta operatori
- Argano a tiro diretto fino a 4 rinvii
- Ventose
- Fari di lavoro su braccio
- Fari di lavoro su carro
- Verricello di traino
- Generatore di corrente
- Cassette di grandi dimensioni amovibili
- Pianalino di carico amovibile
- Motore elettrico trifase 15Kw/400 V
- Piastre maggiorate per stabilizzatori
- Sovrappattini in gomma
- Pattini con gomma vulcanizzata antitraccia
- Olio biodegradabile.

- Hydraulic Jib with opening up to 200°
- Quick-faster hydraulic connection
- Hydraulic line for accessorize
- Manual extensions
- Lowered hook connections
- Lowered connections for vacuum glass lifters
- Two man capacity baskets
- Direct pull winch up to 4th fall
- Vacuum glass lifters
- Led working lamps on the boom
- Led working lamps on the crawler
- Towing winch
- Electric generator
- Removable large box
- Removable load pads
- Three phases electric engine 15 Kw/400 V
- Bigger plates for outriggers
- Rubber pads
- No marking rubber pads
- Green oil.

- Hydraulischer JIB mit 200° Betrieb
- Hydraulische Verbindung
- Hydraulische Verbindungen für Sonderaustattung
- Manuelle Verlängerungen
- Niedrige Anhängervorrichtungen
- Niedrige Anbaustellen für Saugmembranen
- Arbeitskorb für Personen
- Zug – Seilwinde mit 4 Verzögerungen
- Saugteller (Mebranen)
- Arbeitscheinwerfer am Arm
- Arbeitscheinwerfer am Rahmen
- Seilwinde zum Schleppen
- Stromgenerator
- Grosse Staukästen abnehmbar
- Trittbrett abnehmbar
- Elektrischer Motor dreiphasig 15Kw/400V
- Grössere Plattformen für Stabilisatoren
- Überzug der Rollschienen in Gummi
- Rollschienen in vulkanisierter Gummi "spurlös"
- Biologisches abbaubares Öl.

CWE 525^{RT}

	Peso degli elementi Weights Gewichte	Gru standard (Versione 6S) / Standard crane (6S Version)/ Standard Krane (Version 6S) Jib (6S) / Jib (6S) / Jib (6S) Motore elettrico 15Kw/400 V / Electric motor 15 Kw/400 V / Electromotor 15 Kw/400 v Argano / Winch / Seilwinde Zavorra Mobile / Mobile ballast / Abnehmbare Ausgleichsgewichte Pattini in gomma / Rubber pads /Rollschienen in Gummi	15200 Kg 1000 Kg 200 Kg 250 Kg 2200 Kg 420Kg
	Trazione carro cingolato Crawler crane traction Antrieb des Raupenkrans	Trasmissione / Transmission / Antrieb Portata / Scope / Zulässige Traglast Pressione / Pressure / Druck Velocità / Speed / Fahrgeschwindigkeit Pendenza max / Max slope degree / Max. überwindbare Steigung Pressione al suolo / Max pressure on the ground / Bodendruck Larghezza pattino / Traks width / Breite des Läufer Carico max. stabilizzatore / Max. outrigger load / Maximale Belastung des Stabilisatoren	Riduttore Epicicloidale / Moto-reducer/ Planetengetriebe 180 l 255 Bar 1,2 - 2,0 K/h 30° 0,90 Kg/cm ² 450 mm 18000 daN
	Motore diesel Diesel engine Diesel Motor	Marca / Brand / Marke Modello / Model / Typ Potenza max / Max power / Max Leistung Coppia max / Max torque / Maximale Drehemoment Capacità serbatoio / Tank capacity / Tankinhalt	Kubota V3800 TIER IV 84 kw / 112.70 Hp 325 Nm 75 l



RANGE
CWE 525



BGLIFT
by Brennero Gru 





ADVINCERE.COM

Meno centimetri in altezza, lunghezza e larghezza ed un controllo millimetrico di avanzamento, consentono il raggiungimento di luoghi precedentemente preclusi a gru con tali prestazioni. Dimensioni record 5070X1850, H 2615 mm

Less Centimetres in height, Length, Width and a Millimetric Translation Control, permit to the reach places previously inaccessible to other Cranes with Same Performance. Noteworthy sites: 5070X1850, h 2615

Die Niedrige Bauart und Dimensionen 5070X, 1850, h 2615 ermöglichen den Betrieb an Orten wo bisher keine konventionelle Kranfahrzeuge betrieben werden können.

BG LIFT, divisione "Gru compatte" di Brennero Gru, solida realtà produttiva nel settore del sollevamento. BG LIFT è un brand leader estremamente propositivo e fortemente focalizzato verso l'innovazione tecnologica e il design distintivo.

BG LIFT, A Brennero Gru "Compact Crane" division, solid production reality of the lifting branch. BG LIFT is a leader brand, extremely positive, ambitious and deeply focused on technologic innovation and peculiar design.

BG LIFT, Abteilung für "kompakte Kräne" von Brennero Gru, solide Produktgesellschaft im Kran - Sektor. BG LIFT, ist ein Leader-Brand und extrem Ausschau-haltend für Innovation in der Technologie und Design.

BG LIFT
by Brennero Gru 



Brennero Gru Srl
Via Lionello Fiumi, 22
37010 Cavaion Veronese (VR) Italy
Phone: +39 045 6260100
e-mail: info@bglift.com

www.bglift.com

R A N G E
CWE 525